

INSTALLATION INSTRUCTIONS

DESCRIPTION: Front Skid Plate
PART NUMBER: 2MB-F84N0-T0
MODEL: Wolverine



⚠ WARNING

Please read and understand these instructions completely before installation to avoid possible injury, or damage to the accessory or vehicle.

NOTICE:

This installation requires a torque wrench and should be performed by an authorized Yamaha dealer or other qualified technician.

WARRANTY INFORMATION:

Genuine Yamaha Accessories are covered by a one-year limited warranty against defects in material or workmanship. Labor for replacement of defective components is not covered. See your Yamaha dealer for a copy of the warranty statement.

DEALER OR INSTALLER:

These instructions contain important information for future reference and *must* be given to the customer.

PARTS LIST:

No.	Part Number	Description	Qty
--	2MB-F84N0-T0	Front Skid Plate	--
①	*	Front Skid Plate	1
②	*	Hex Bolt w/Washer	6
③	*	U-Nut	2

* Part supplied with kit only and not available separately.

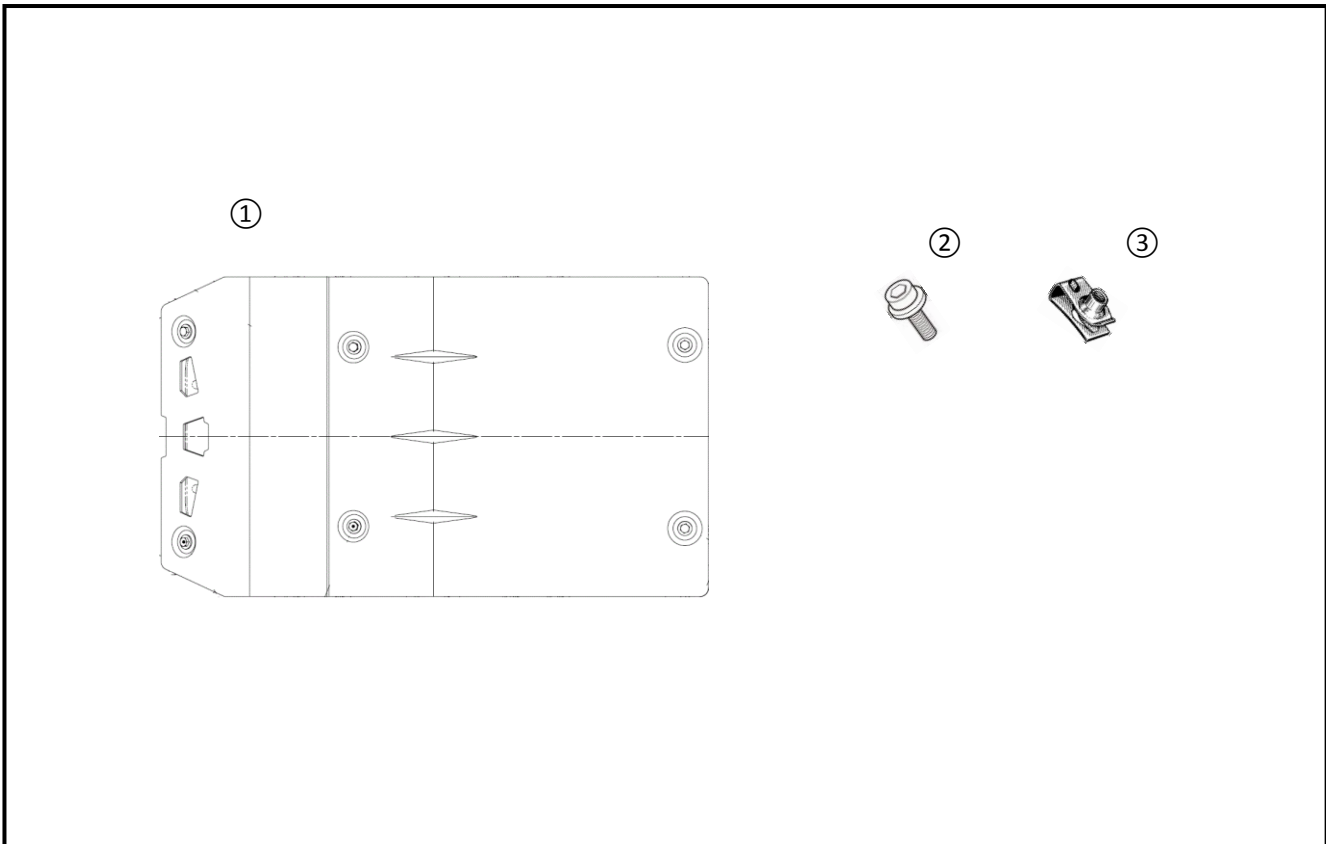

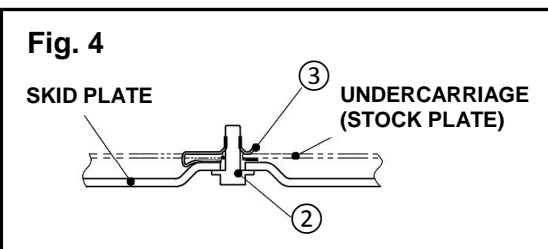
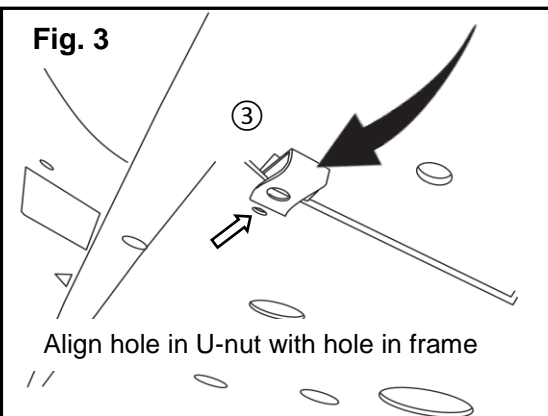
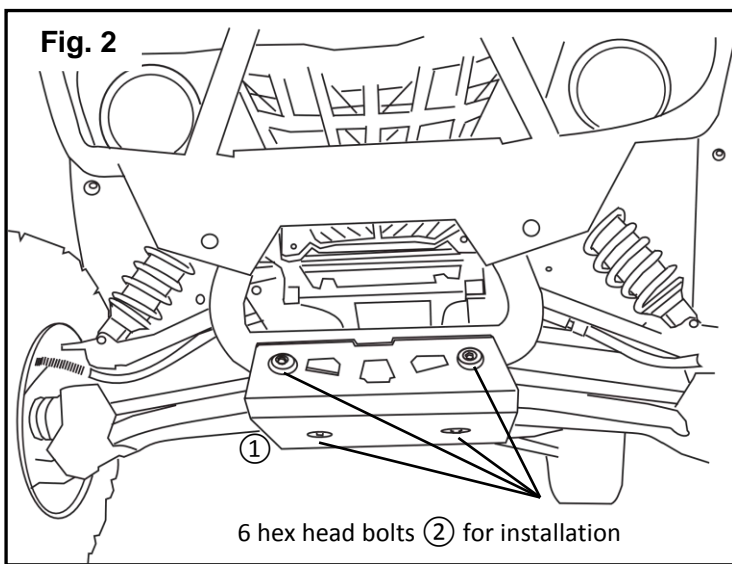
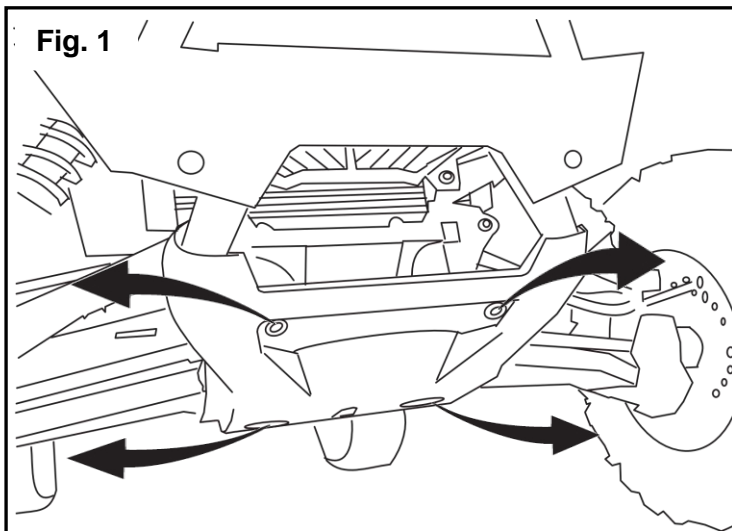

PREPARATION:

- Place the vehicle on a secure and level surface.
- Set the parking brake and clean the mount surfaces before starting installation.

INSTALLATION:

TIP: Have an assistant help hold the plates in place while installing bolts.

1. Start in the front of the vehicle, remove the 4 bolts that secure the stock front skid plate (Fig. 1). Remove the front skid plate. The bolts will not be used in this installation.
2. Fit up the front skid plate (1) to the frame. Note positions of the 4 threaded holes on the frame and the two square spaces to the rear. Install two U-nuts to these square spaces as shown in Fig. 3 and Fig. 4.

TIPS: The threaded part of the U-nut is always 'inside' the frame. The hole in the U-nut aligns with the hole in the frame, as shown in Fig.3.

3. Use 6 Hex Bolts w/Washers (2) to attach the Front Skid Plate (1) to the 4 threaded holes in the front and the 2 rear U-nuts (3). Leave these hand tight (Fig. 2).
4. Adjust the position of the skid plate to your preference. When you are satisfied with the fit, torque the bolts to 8.5 Nm (0.85 m-kgf, 6.0 ft-lbf).

MAINTENANCE:

Periodically, check torque and tightness on hardware. If found loose, re-torque or re-tighten.

CARE AND CLEANING:

Clean metal parts with a clean soft cloth and mild soap and water. Rinse and dry.

CUSTOMER SERVICE:

For further information see your Yamaha dealer.

ESTIMATED TIME TO INSTALL: 0.5 HR